



H.B. Fuller

Window

backbedding sealant

from H.B. Fuller

HL-5200 backbedding sealant is specifically designed to help optimize your lean manufacturing process.

HL-5200 is a fast-setting, 100% solids, single-component sealant, designed for use in backbedding operations. It is equally well-suited for use in the automatic or semi-automatic manufacture of aluminum, vinyl or wood sash windows. This warm-applied, patent pending sealant meets AAMA 800 performance requirements.

Once applied, HL-5200 sealant instantly delivers a high-strength bond that allows your windows to advance to the next processing step. This not only saves time and precious floor space, it helps move your production from a batch to a continuous process for

improved throughput. Making HL-5200 sealant part of your lean manufacturing operation saves you time, money, floor space and labor!

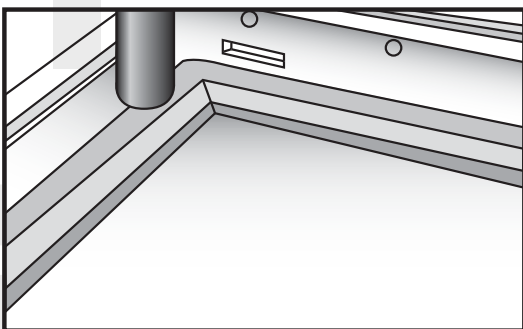

Instant handling strength allows assembled windows to ship immediately.



Only HL-5200 backbedding sealant offers the advantages of immediate handling strength, workable open time and low modulus.

HL-5200 advantages are unsurpassed!

- **Excellent green strength**—Immediate holding power keeps glass in place to keep your process moving without having to wait for chemical cure.
- **Superior throughput**—When you do not need to wait for the sealant to dry or cure, you continuously step-up production.
- **Longer open time**—Long enough to allow for glass repositioning if necessary, but not too long to require holding before handling.
- **Friendly to the environment and to manufacturing**—The 100% solids product contains no volatile organic compound (VOC). There is no need for meter mixing equipment.
- **Flexible after curing for improved durability**—Low modulus gives flexibility so the sealant acts like a shock absorber to cushion glass should flexing occur during installation, storms or high winds. You will see superior structural integrity.
- **Fewer issues after installation**—A flexible cushion means less stress cracking of the glass. Excellent cold temperature resistance means longer life, less degradation and shrinkage. You will have fewer warranty headaches and returns.
- **Deglazeable**—It is easy to repair windows in the field should the glass break. Other sealants may prevent the removal of the pane, and may require a whole new window replacement.
- **Good adhesion to typical sash construction materials**—Excellent adhesion to PVC and aluminum sash materials. Exceptional resistance to wood rosin yields lasting bonds to wood frames. One sealant for all these sashes!
- **More economical than manual tape glazing**—Eliminates the tape and necessary handling. You will experience faster throughput and improved handling strength with fewer workers and less raw material.

Works on your standard or customized equipment. Easy to use and dispense.

HL-5200 sealant works on all window manufacturing equipment, X-Y glazing tables and sealant applicators and dispensers. Its single-component chemistry eliminates mixing. Uncured sealant cleans up with common solvents. Shipped in drums or pails for easy transfer and storage.

PRODUCT SPECIFICATIONS HL-5200 sealant contains no VOCs and has excellent UV and cold weather resistance. It has a low modulus for outstanding flexibility. It is odorless, and its gray or black color makes visual inspection during assembly easy.

Color	Gray/Black	
Application Temperature	128° -138°C	
Form and Packaging	Solid/Drums/Pails	
Raw Material Base	Moisture cure polymer	
Viscosity @ 121°C	250,000 cps (mPA.s)	
Hardness — Shore A	ASTM C66150 50	
Peel Adhesion	ASTM C794 To glass: 35 kN/m To aluminum: 35 kN/m	
Tensile Strength	ASTM D624 Modulus @ 100%: 0,50 MPa Ultimate Elongation: 300%	
Green Strength	15 minutes: 0,22 MPa 60 minutes: 0,26 MPa	
Lap Shear	PVC-glass: 0,59 MPa	
Open Time	3 minutes	
Tear Resistance	ASTM D624 61 kN/m	
Specific Gravity	1,12g/cm³	

Choose from a variety of window manufacturing products and services from H.B. Fuller.

H.B. Fuller has been delivering innovative solutions to the window industry for over 30 years. Our products are chosen by major window manufacturers around the world. H.B. Fuller patented and patent pending products include adhesives, caulks, desiccants, edge sealants, applicators and dispensers. H.B. Fuller's unmatched expertise will help you improve your window manufacturing operation.

Call your H.B. Fuller representative for more information.

Call 1-888-HBFULLER for a free, no obligation audit or more information.



H.B. Fuller

H.B. Fuller
1200 Willow Lake Blvd.
St. Paul, MN 55110
1-888-HBFULLER
www.hbfuller.com